



CHIPPING NORTON TOWN COUNCIL

TOWN HALL, CHIPPING NORTON, OXFORDSHIRE OX7 5NA

TEL: 01608 642341

Email: townclerk@chippingnorton-tc.gov.uk

Office Hours: Mon/Weds/Fri, 9am-5pm

TOWN CLERK: Katherine Jang

2nd June 2026

SUMMONS TO ATTEND A MEETING OF CHIPPING NORTON TOWN COUNCIL

TO: All Members of Chipping Norton Town Council

VENUE: Lower Hall, Chipping Norton Town Hall

DATE: Monday 8th June 2026

TIME: 6:30pm

Cllrs. Sandra Coleman (Town Mayor) Steve Akers (Deputy Mayor), Cora Schor-Brener, Ben Bibby, Mike Cahill, Tom Festa, Ian Finney, Jo Graves, Alex Keyser, Dom Rickard, Athos Ritsperis, Michael Rowe, Mark Walker, Emily Weaver, Sharon Wheaton and Natasha Whitmill.

Katherine Jang
Town Clerk

Recording of Meetings

Under the Openness of Local Government Bodies Regulations 2014 the council's public meetings may be recorded, which includes filming, audio-recording as well as photography.

A G E N D A

1. Apologies for absence.

To consider apologies for absence.

Committee members who are unable to attend the meeting should notify the Town Clerk (townclerk@chippingnorton-tc.gov.uk) prior to the meeting, stating the reason for absence.

2. Declaration of interests.

Members are reminded to declare any disclosable pecuniary interests in any of the items under consideration at this meeting in accordance with the Town Council's code of conduct.

3. Minutes

To approve the minutes of the annual Council Meeting held on 11 May 2026.

4. Public Participation

The meeting will adjourn for this item

Members of the public may speak for a maximum of five minutes each during the period of public participation.

5. West Oxfordshire District Councillors update

To receive any updates and information from Chipping Norton's Ward Councillors sitting on WODC.

6. Oxfordshire County Councillors update

To receive any updates and information from Chipping Norton's Ward Councillors sitting on WODC.

7. Chipping Norton development

To receive an update on the status of the Chipping Norton Development.

8. Cotswold Crescent

To receive a proposal from West Oxfordshire District Council for an outdoor classroom at Cotswold Crescent play area

9. Civic announcements

To receive a report from The Mayor on Civic engagement and activities.

10. Reports from representatives of outside bodies

To receive an update from members who sit on outside bodies.

11. To receive the accounts and balance sheet for 2025-26

To receive the accounts for year ending 31st March 2026.

12. To receive the internal audit reports for 2025-26

To receive and note a report from the internal auditor.

13. AGAR Section 1 – Governance Statements

To approve the AGAR Section one Governance Statement. Once approved the statement should be signed by the Town Clerk and the Mayor

14. AGAR Section 2 – Accounting Statements

To approve the AGAR Section two Accounting Statements. Once approved the statements should be signed by the Town Clerk and the Mayor.

15. Notice of public rights and the publication of the AGAR

For Council to note the issue of the Notice of Public Rights and the Publication of the Annual Governance and Accountability Return.

16. Correspondence

To receive any correspondence and agree next steps.

- a. To receive a proposal for Andy's Man Club
- b. To receive a request for free use of Glyme Hall for a screening of the National Climate Emergency Briefing
- c. To note a survey launched by MP Sean Woodcock about "Chipping Norton Improvement"
- d. To receive correspondence from OCC regarding renewable energy payments
- e. To receive correspondence from Chipping Norton Age Concern about their change of charitable objects

17. Town Hall Restoration Sub-Committee

To consider the draft Terms of Reference for the creation of a new sub-committee

18. Planning Applications

To receive a schedule of planning applications from West Oxfordshire District Council.

19. Confidential Session

To resolve to move into a Confidential Session to discuss Separate Business, pursuant to s.1(2) of the Public Bodies (Admission to Meetings) Act 1960. The public and press should leave the meeting during the consideration of item 12.

20. Mayor's Medals

- a. To receive and consider quotations for the purchase of a Mayor's badge, Councillor

badges, and Past Mayor badges

21. Date of the next meeting – Monday 21st July 2025



CHIPPING NORTON TOWN COUNCIL
TOWN HALL, CHIPPING NORTON, OXFORDSHIRE, OX7 5NA

TEL: 01608 642 341

Email: Townclerk@chippingnorton-tc.gov.uk

Office Hours: Mon/Weds/Fri, 9am-5pm

Minutes of the Annual Meeting of Chipping Norton Town Council, held on the 11th
May 2026 at 6:30pm in the Upper Hall, Chipping Norton Town Hall

PRESENT: Cllrs Sandra Coleman (Town Mayor), Dom Rickard, Alex Keyser, Sharon Wheaton, Emily Weaver, Steve Akers, Jo Graves, Mark Walker, Michael Rowe, Athos Ritsperis

ALSO PRESENT:

Katherine Jang, Town Clerk & CEO
Louise Warren, Responsible Finance Officer and Deputy Clerk
Cllr Geoff Saul, OCC and WODC
Terry Palmer, Town Hall Keeper and Ceremonial Macebearer
6 Members of the public

FC1. Election of Town Mayor 2026/27

Members received nominations for the election of Town Mayor 2026-27. Cllr Akers proposed Cllr Coleman, seconded Cllr Graves.

No other nominations were received.

All in favour, motion carried.

RESOLVED: That Cllr Sandra Coleman is elected Town Mayor for the municipal year 2026-27 and signed the Declaration of Acceptance of Office.

FC2. Election of Deputy Mayor 2026/27

Members received nominations for the election of Deputy Mayor 2026-27. Cllr Coleman proposed Cllr Akers, seconded by Cllr Weaver.

No other nominations were received.

All in favour, motion carried.

RESOLVED: That Cllr Akers is elected Deputy Mayor for the municipal year 2026-27 and signed the Declaration of Acceptance of Office.

FC3. Apologies for absence

Apologies were received from Cllrs Tom Festa, Ian Finney, Mike Cahill, Cora Schor-Brener, and Ben Bibby.

FC4: Declaration of interests

None received

FC5. Minutes



CHIPPING NORTON TOWN COUNCIL
TOWN HALL, CHIPPING NORTON, OXFORDSHIRE, OX7 5NA

TEL: 01608 642 341

Email: Townclerk@chippingnorton-tc.gov.uk

Office Hours: Mon/Weds/Fri, 9am-5pm

Members considered the minutes of the Full Council meeting held on 23rd March 2026. No amendments were proposed.

RESOLVED: That the Chair signs the minutes as an accurate record.

FC6. Public Participation

None received.

FC7. Minutes and reports from Committees

Members considered recommendations from the Committee and Sub-Committee meetings held on:

a. Traffic Advisory Sub-Committee, 26th March 2026

Members considered a recommendation from the Sub-Committee to approve the installation of a new SID on Burford Road, and replacement of existing VAS on London Road.

Cllr Coleman proposed to accept the recommendations, seconded by Cllr Rickard, All in favour. Motion carried.

RESOLVED: That the installation of a new SID on Burford Road and replacement of existing VAS on London road are approved.

FC8. Welcome to the new District Councillor

Cllr Walker introduced this agenda item as a representative of West Oxfordshire District Council and welcomed Cllr Coleman as Chipping Norton's second District Council representative.

FC9. Policing Matters

a. Cllr Wheaton presented a verbal update on local policing matters in the absence of PCSO Wes Smith as he had been called away to another parish meeting. Cllr Wheaton noted that the crime in Chipping Norton had been similar over the past few months and that there had been a significant decline in the theft from vehicles.

b. Members considered nominations for Council representatives to liaise with TVP and provide regular updates to Council.

Cllr Coleman asked if Cllr Wheaton would be happy to carry on with the role for another year, which Cllr Wheaton agreed and noted that she has enjoyed building links with the Thames Valley Police. Cllr Coleman proposed that Cllrs Wheaton and Cahill carry on as TVP liaisons for CNTC, seconded by Cllr Graves. All in favour, motion carried.

RESOLVED: That Cllrs Wheaton and Cahill are appointed as TVP liaisons for the municipal year 2026-27.

FC10. Chipping Norton Development

Members received communication from the Chipping Norton Skatepark CIC requesting that the Town Council signs a letter of support for the proposed Skatepark on New Street and the proposed Community Sports Hub on OCC/Field Reeves land.

Cllr Ritsperis asked if the proposal for the new Community Sports Hub might limit the opportunities for a new Secondary School in town. The Town Mayor replied that it would not as the land is also owned by the Field Reeves and would not be a natural fit for a



CHIPPING NORTON TOWN COUNCIL
TOWN HALL, CHIPPING NORTON, OXFORDSHIRE, OX7 5NA

TEL: 01608 642 341

Email: Townclerk@chippingnorton-tc.gov.uk

Office Hours: Mon/Weds/Fri, 9am-5pm

new school in that location.

Cllr Coleman proposed that the Council gives authority to the Town Clerk to sign the letter on the Town Council's behalf, seconded by Cllr Graves. All in favour, motion carried.

RESOLVED: That the Town Clerk is authorised to sign the letter of support for the new skatepark and proposed Community Sports Hub on behalf of the Town Council.

FC11. Civic Announcements

Members received a report from The Mayor on Civic engagement and activities. Cllr Coleman gave a quick update on the Town Council's recent charity fundraiser on behalf of the Chippy Larder, which raised over £1,000.

FC12. Correspondence

None received.

FC13. Standing Orders

Members considered and reviewed the Council's Standing Orders for 2026-27. Cllr Coleman proposed to accept the amended Standing Orders, seconded by Cllr Walker. All in favour, motion carried.

RESOLVED: That the Council adopts the Standing Orders for 2026-27.

FC14. Scheme of Delegation.

Members considered and reviewed the Scheme of Delegation (including terms of reference for Committees) for 2026-27.

Members requested that a Disposal policy and procedure to be brought to the next Full Council meeting for approval. No other amendments were proposed.

Cllr Coleman proposed to adopt the Scheme of Delegation as proposed, seconded by Rickard. All in favour, motion carried.

RESOLVED: That the Council adopts the Scheme of Delegation for 2026-27.

FC15. Financial Regulations

Members considered Council's Financial Regulations 2026-27 as reviewed by the Finance and Resources Committee.

Cllr Coleman proposed to accept the Financial Regulations without further amendment, seconded by Cllr Weaver. All in favour, motion carried.

RESOLVED: That the Council adopts the Financial Regulations 2026-27.

FC16. Code of Conduct

Members noted the Councillors Code of Conduct.

FC17. General Power of Competence

Members reaffirmed that the Council meets the criteria to exercise the General Power of Competence.

Cllr Graves proposed to reaffirm the statement confirming GPC as stated below, seconded by Cllr Ritsperis. All in favour, motion carried.



CHIPPING NORTON TOWN COUNCIL
TOWN HALL, CHIPPING NORTON, OXFORDSHIRE, OX7 5NA

TEL: 01608 642 341

Email: Townclerk@chippingnorton-tc.gov.uk

Office Hours: Mon/Weds/Fri, 9am-5pm

RESOLVED: That Chipping Norton Town Council hereby confirms we meet the eligibility criteria for adoption of a General Power of Competence as defined in the Localism Act 2011 and SI 965 The Parish Councils (General Power of Competence)(Prescribed Conditions) Order 2012. We further resolve to adopt a General Power of Competence. If adopted, the GPC will remain in place until the annual meeting to be held in May 2027 immediately after Town council elections are concluded. If then, again approved, it will remain in force until the annual meeting immediately following the next elections for the Town council.

FC18. Appointment of Members to Standing Committees and Sub-Committees

Members discussed appointment to the Standing Committees and Sub-Committees for the municipal year 2026/27.

Standing Committee Membership 2026-27

Community Committee	Finance & Resources Committee	Strategic Planning Committee
Town Mayor (ex-officio) Sandra Coleman	Town Mayor (ex-officio) Sandra Coleman	Town Mayor (ex officio) Sandra Coleman
Athos Ritsperis	Athos Ritsperis	Alex Keyser
Ben Bibby	Dom Rickard	Dom Rickard
Jo Graves	Natasha Whitmill	Ian Finney
Michael Rowe	Emily Weaver	Jo Graves
Alex Keyser	Ben Bibby	Mark Walker
Emily Weaver	Ian Finney	Michael Rowe
Steve Akers		Sharon Wheaton
		Tom Festa
		Cora Schor-Brener
		Steve Akers

Sub-Committee Membership 2026-27

Planning Sub-Committee	Traffic Advisory Sub-Committee	Staffing Sub-Committee
Sandra Coleman	Alex Keyser	Steve Akers
Dom Rickard	Jo Graves	Ian Finney
Ian Finney	Mark Walker	Jo Graves
Michael Rowe	Sandra Coleman	Natasha Whitmill
	Steve Akers	Sandra Coleman
	Tom Festa	Tom Festa
	Cora Schor-Brener	

Cllr Akers proposed to accept the membership to committees and sub-committees as outlined above, seconded by Cllr Walker. All in favour, motion carried.

RESOLVED: That the Council appoints membership for Committees and Sub-



CHIPPING NORTON TOWN COUNCIL
TOWN HALL, CHIPPING NORTON, OXFORDSHIRE, OX7 5NA

TEL: 01608 642 341

Email: Townclerk@chippingnorton-tc.gov.uk

Office Hours: Mon/Weds/Fri, 9am-5pm

Committees 2026-27 as outlined above in FC18.

FC19. Representatives to Outside Bodies

Members discussed appointment of Council representatives to outside bodies for 2026-27.

Welfare Charities	Field Reeves	William Fowler Allotments Trust
Town Mayor (ex-officio) Sandra Coleman	Town Mayor (ex-officio) Sandra Coleman	Town Mayor (ex-officio) Ben Bibby
Emily Weaver	Jo Graves	Emily Weaver
Ben Bibby	Dom Rickard	Sharon Wheaton
Dom Rickard	Natasha Whitmill	Alex Keyser
	Alex Keyser	Jo Graves
		Ian Finney

Cllr Weaver proposed to appoint Council representatives to outside bodies as outlined above, seconded by Cllr Akers. All in favour, motion carried.

RESOLVED: That the Council appoints representatives to outside bodies 2026-27 as outlined above in FC19.

FC20. Risk Register

Members received the Council's Corporate risk register and risk management policy as reviewed by the Finance & Resources Committee.

Cllr Coleman proposed to accept the recommended risk register and risk management policy, seconded by Rickard. All in favour, motion carried.

RESOLVED: That the Council adopts the Corporate Risk Register and Risk Management Policy 2026-27.

FC21. Asset Register

Members received the Council's asset register as reviewed by the Finance & Resources Committee.

Cllr Coleman noted that this asset register is a work in progress. Cllr Coleman proposed to accept the Council's asset register, seconded by Cllr Wheaton. All in favour, motion carried.

RESOLVED: That the Council adopts the Asset Register 2026-27.

FC22. Terms and Conditions of hire

Members received the amended Terms and Conditions of hire for the Council's venues as reviewed by the Community Committee.

Cllr Graves proposed to accept the Terms and Conditions of hire as amended, seconded by Ritsperis. All in favour, motion carried.

RESOLVED: That the Council adopts the Terms and Conditions of hire for the Council's venues 2026-27.

FC23. Planning Applications



CHIPPING NORTON TOWN COUNCIL
TOWN HALL, CHIPPING NORTON, OXFORDSHIRE, OX7 5NA

TEL: 01608 642 341

Email: Townclerk@chippingnorton-tc.gov.uk

Office Hours: Mon/Weds/Fri, 9am-5pm

26/00749/LBC: Internal alterations to include removal of stud wall, blocking up of internal doorway and replacement of kitchen units (retrospective)

LOCATION: 5 Norton Park, Cotshill Gardens, Chipping Norton

No objection, no comment

26/00759/FUL: Overclad existing double pitched roof using single skinned profiled metal sheeting including barge eaves and ridge flashings with the re-use of existing gutters and downpipes and the insertion of new roof lights. LOCATION: Jewson Building Supplies, Station Road, Chipping Norton

No objection, no comment

26/00792/ADV: Replacement hanging (externally illuminated) and wall sign together with fascia sign (Externally illuminated) and awning, all to front elevation.

LOCATION: 6 Market Place, Chipping Norton

No objection, no comment

FC24. Date of the next meeting – Monday 8th June 2026

District Councillor's Report

Firstly I would like to thank residents who supported me at the recent election. During my campaign I spent time talking to many of you on the doorstep and look forward to serving our town at the District Council.

I have been appointed to the Executive and given the portfolio for Stronger, Health Communities. This means that I will have responsibility for:

- Community and public health
- Community provision of community space/hubs with town & parish partnership
- Promotion of investment grants support through platform partnership funding
- Assets of community value – strategic overview
- Refugee Resettlement Programme
- Young people
- Equality and diversity
- Voluntary sector engagement
- Safeguarding

My first responsibility under this portfolio was to meet with the Overview and Scrutiny Committee to discuss new arrangements for grant funding using Crowdfunder to replace the current Westhive programme. This was well received by the committee as the new programme has less costs for applicants than the existing arrangements. Local organisations who want to apply will be well supported by WODC officers throughout the process and there will be two funding rounds each year.

The Refugee Resettlement Programme has been facilitated by Asylum Welcome and is coming to an end with the closure of the hotel accommodation in Witney, but the Council remain committed to supporting refugees. In recognition of this commitment, I have authorised a donation of used laptops to school students from this community via the Oxford IT Bank.

The District Council continues to work on the new Local Plan and the Regulation 19 draft will be published in July.

Sandra Coleman

CHIPPING NORTON TOWN COUNCIL

Agenda item 8 – Cotswold Crescent Play Area: Nature Connected project

Report Authors – Martha Holland (Healthy Communities Officer) and Tatiana Bell (Nature Recovery Officer), West Oxfordshire District Council

Purpose of the paper

To seek the Council's approval, with permission from Cottsway Housing as leaseholder, for an improvement project to be delivered in partnership with Oxfordshire County Council and West Oxfordshire District Council using Public Health, Healthy Place Shaping funding.

The project relates to:

- Installation of an outdoor classroom at Cotswold Crescent Play Area

The project would be externally funded and delivered in partnership with the Town Council.

Context

Countless research papers have found that an increased connection to nature and greenspaces may have co-benefits including positive impacts to mental and physical health, social connection and emotional wellbeing ([Harrison, 2023](#)).

Communities facing higher levels of socio-economic deprivation are faced with increased risks of mortality, chronic disease, disparities in food consumption, and poorer mental and physical health ([Diez Roux, 2001](#)).

Recent research has found that communities facing higher levels of socio-economic deprivation often also have less access to greenspace ([Mears et al., 2019](#)) and this has been found in Oxfordshire ([Crockatt et al., 2023](#)).

Research has also found that communities facing higher levels of deprivation receive greater benefits from greenspaces compared to their more affluent counterparts ([Roe et al., 2013](#)).

Project aim

The scope of the Nature Connected project is to improve nature recovery in areas with higher levels of deprivation. The areas were identified using the 2019 and 2025 Index of Multiple Deprivation (IMD) produced by the UK Department for Levelling Up, Housing and Communities.

Target location – Chipping Norton

Chipping Norton is a dynamic town, recently facing large amounts of growth. The 2025 Index of Multiple Deprivation data identified the southern section of the town, in the 30th percentile most deprived in the country.

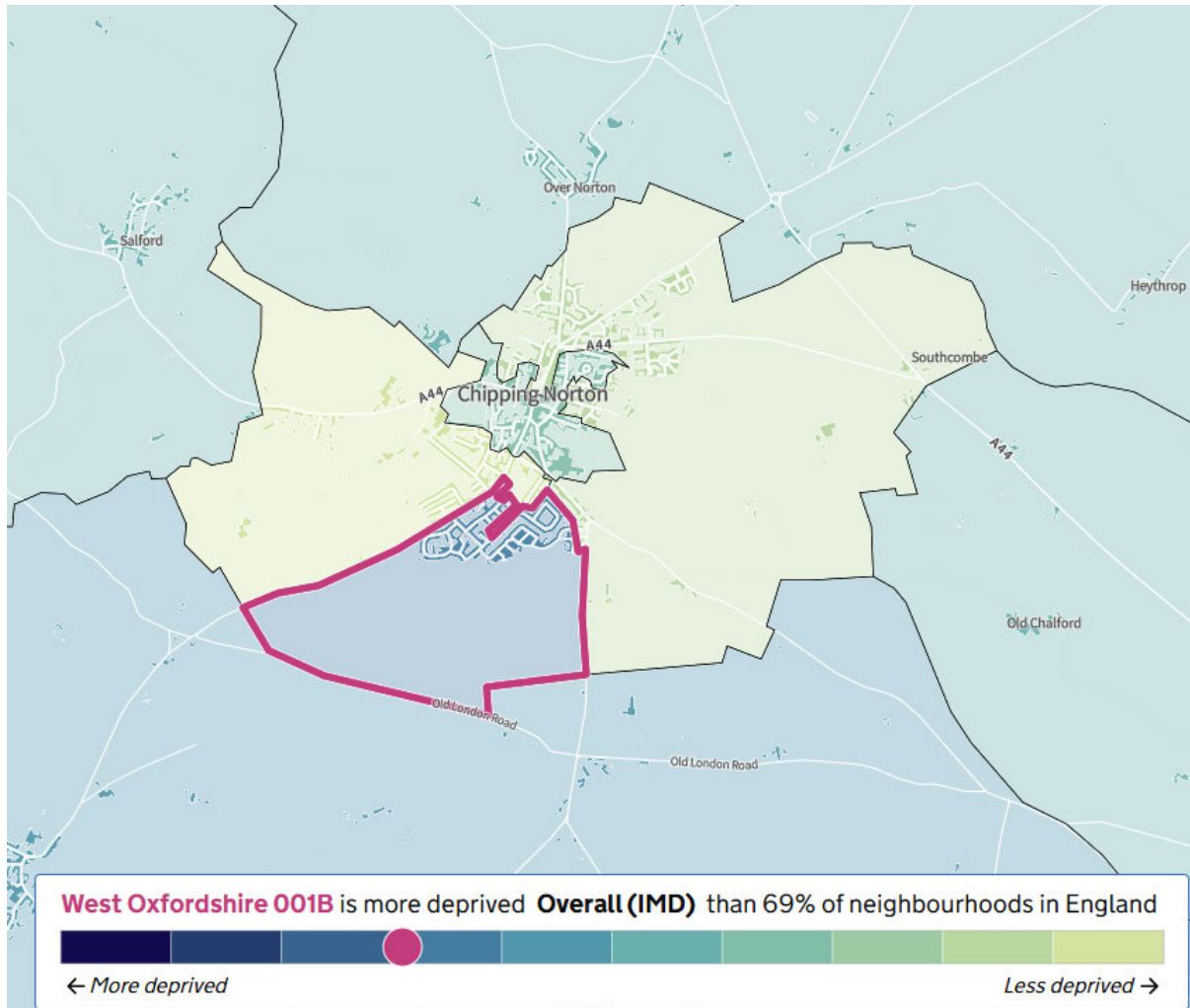

Project activities

The Nature Connected project has built relationships with Link2Sustain/Sustainable Chipping Norton who are supporting this community with a Youth Group at Cotswold Crescent. This project has run several activities to build interest in nature recovery with the young people. These have included making cyanotype prints at the 2025 Cotswold Crescent Play Day, a visit to Little Rollright Farm, Andy Goldsworthy inspired art and Suminagashi puddle prints. These activities have helped to get young people outdoors and connecting with greenspaces, as well as learning new skills and opening new potential career paths.

As well as offering funding for further sessions at Cotswold Crescent Play Area, the Nature Connected project would like to co-design with the young people an outdoor classroom for the Play Area. This will increase the accessibility of the site, making it useable all year round, and foster local ownership of the site.

Design ideas

'Young people have said yes to having a shelter in the park. They said it would mean they would use the park more, spend more time with their friends there and be able to do more activities like football even when there are [rain] showers.'

Example shelters:



Key things that **could** be included:

- Half sides
- Seating
- Detachable canvas wall/awning - to extend the covered area especially in heat waves
- Hardened flooring - vital in the wetter months

This design like the one at Fairytale Farm was suggested by the youth group.



Suggested location:



Financial implication

There are no direct financial costs to Chipping Norton Town Council associated with the project outlined in the paper. The design and installation of the outdoor classroom will be funded through Oxfordshire County Council Public Health funding and delivered by West Oxfordshire District Council.

Recommendation

Council is requested to grant permission for the following project to proceed on land leased from Cottsway Housing:

Installation of an outdoor classroom at Cotswold Crescent Play Area, to be commissioned and delivered by West Oxfordshire District Council using Oxfordshire County Council Public Health funding.

Mayor's Report June 2026

This coming year our Council will continue our major projects to renovate and restore our Town Hall, initially working on planning and fundraising and to provide a wheeled sports facility. We will continue to improve our green spaces and advocate for local residents regarding the Local Plan. I would also encourage local groups with suitable projects to apply to our grants programme for financial support as the next applications will be reviewed on 13th July by the Finance Committee and to encourage all residents to nominate others for our Town Awards to be made in the autumn. Our team can be contacted by email office@chippingnorton-tc.gov.uk or face to face at the town Hall reception desk on Monday, Wednesday and Friday.

We will be holding our next Keep Chippy Beautiful Litter Pick on Saturday 27th July, followed by two new sessions to carry out other practical tasks such as sign cleaning and weeding on Tuesday 30th June and Tuesday 7th July. Please join us if you are able.

Mayor's Diary:

6 th May	Allotment Administrator Interviews
11 th May	Annual Meeting of the Council
21 st May	Meeting with William Fowler Allotment Committee
28 th May	Staffing Committee

Dates to note:

15 th June	Refugee Nation Flag Amnesty	10am
24 th June	Reserves Day Flag RBL	7pm
26 th June	Councillor Surgery at Penhurst	10am
27 th June	Keep Chippy Beautiful Litter Pick	10am
30 th June	Keep Chippy Beautiful Clean Up 1	10am
6 th July	NHS Flag	10am
7 th July	Keep Chippy Beautiful Clean Up 2	10am

Police and local crime report for Council on June 08, 2026

Cllr Cahill and Cllr Wheaton met with PCSO Wesley Smith on 25th May at Chipping Norton Fire station. It was good to see the set up there. We wanted to fact find for the months March – May 2026 and look ahead to the summer.

The town is served by two PCs and two PCSO's. The feeling from the police side of things is that this is a healthy ratio. Inspector Chris Ball has been promoted and we wish him well. A new Inspector will be in place sometime in June.

There continues to be an **increase in house burglary**, with as many as two incidents per week; not in the town itself, but in the surrounding villages. There is a pattern: mostly dwellings that are unoccupied because people are on holiday or are fully furnished second homes that are unattended. The perpetrators are focused on cash, jewellery and cars. These break ins have been heavy handed, with forced entry and ransacking to find what they want; which is extremely distressing. Of course, with the hot weather doors and windows are being left open which is good news for the gangs. Please encourage residents to be vigilant, power tools and garden machinery are also vulnerable in the Summer months.

Shoplifting continues to be down in our Town Centre, which is pleasing. Shopkeepers are being reminded to report crime through the DISC app which saves them a lot of time compared with dialling 101. We are planning to run a training session in the use of DISC in the premises of individual retailers.

There has been a reduction in incidents of **anti-social behaviour**; it will be interesting to see if there is an increase with the Summer ahead, and the World Cup. Cases of ASB and domestic violence do tend to spike when these big events are on. Officers will be liaising with licensees about possible variations in opening hours.

The Vagrancy and Begging Act has been updated, and it is no longer an offence to beg; this is now classified as ASB. Our town police are very sure that most incidents of begging in and around the High Street are due to individuals that are brought in by organised gangs from Oxford. They are not interested in acts of kindness as much as cash. An incident recently proved the point when a young woman begging was bemoaning the fact that she could not feed her baby. After a very nice person went into Boots and purchased baby formula, the young woman later returned to Boots to try to exchange the formula for money.

As I walk down **Spring Street** most days, I am always deeply frustrated when I see vehicles parked up on the pavement or just left on the double yellow lines. My main concern is that emergency vehicles need to be able to get through.

When a vehicle is parked on a double yellow line the offence falls under the Traffic/Parking Wardens' jurisdiction. Our local police do not have the authority to reprimand and fine the owner, although traffic police do.

If the vehicle is parked on the pavement causing an obstruction to passers-by, then this does fall under the attention of our local police.

An obstruction by a vehicle left on a pavement or on a double yellow line is an obstruction, especially when it stops the free flow of other cars. I fear there is a loophole here and did bring this up.

The **Cereals Event** is nearly upon us, opening at Diddly Squat to coincide with the new series of Clarkson's Farm. It will take place on Wednesday and Thursday, the 10th and 11th of June. Large numbers of invited industry representatives are expected, with as yet no briefing for our local police. Hopefully there will be a positive knock-on effect in the town for our traders and publicans/ restaurant owners.

Sharon Wheaton May 26

Income & Expenditure by Budget 31/03/2026

Month No: 12

Account Code Report

	Actual Year to Date	Current Annual Bud	Budget Variance	Committed Expenditure	Funds Available
<u>Income</u>					
3100 Precept Income	494,204	494,204	0		
3110 Rents Receivable	2,127	2,540	413		
3111 Rugby Club Right Of Access	175	175	0		
3115 Lettings Income	87,942	125,000	37,058		
3140 WODC Water Rates Contrib	0	100	100		
3170 Grant Income	6,130	0	(6,130)		
3180 Interest Receivable	10,175	25,000	14,825		
3190 Interments & Memorials	5,750	7,000	1,250		
3191 Grave Purchase	3,035	1,000	(2,035)		
3210 Admin Charges	4,801	9,600	4,799		
3230 Manorial Land (Pace Petroleum)	18,750	15,000	(3,750)		
3290 Miscellaneous Income	129,007	0	(129,007)		
3320 S106/grant income	3,243	0	(3,243)		
3331 Bar income	3,354	3,000	(354)		
Total Income	768,692	682,619	(86,073)		
<u>Direct Expenditure</u>					
Total Direct	0	0	0	0	
<u>Overhead Expenditure</u>					
4100 Salaries/Superann/Nl	335,215	364,500	29,285		29,285
5110 Stationery	465	1,000	535		535
5120 Photocopying Costs	2,012	3,200	1,188		1,188
5140 Promotion	528	1,500	972		972
5200 Postage	29	100	71		71
5210 Telephone and Comms	12,413	11,000	(1,413)		(1,413)
5310 Office Equipment	1,019	500	(519)		(519)
5322 Expenses	10	0	(10)		(10)
5340 Website Costs	1,139	1,000	(139)		(139)
5360 Computer Hardware/Software	4,154	3,000	(1,154)		(1,154)
6110 Heat and Light	22,758	17,000	(5,758)		(5,758)
6130 Water & Sewerage	2,446	3,350	904		904
6200 Rent	27,479	35,150	7,671		7,671
6210 Rates	29,563	46,300	16,737		16,737
6230 Window Cleaning	1,258	850	(408)		(408)
6240 Alarm/Fire Extinguisher Insp	9,603	3,000	(6,603)		(6,603)
6310 Cleaning / Sanitary Expenses	8,921	5,000	(3,921)		(3,921)
6319 PWLB Repayment	7,613	0	(7,613)		(7,613)
6320 Vehicle Hire	69,539	8,500	(61,039)		(61,039)
6321 Vehicle Insurance	3,775	1,200	(2,575)		(2,575)

Month No: 12

Account Code Report

	Actual Year to Date	Current Annual Bud	Budget Variance	Committed Expenditure	Funds Available
6322 Fuel	1,691	1,200	(491)		(491)
6323 Machinery Hire	59,361	10,000	(49,361)		(49,361)
6324 Tools & Equipment	5,972	200	(5,772)		(5,772)
6325 PPE	2,182	1,500	(682)		(682)
6330 Waste Disposal	4,331	4,800	469		469
6400 Repairs and Maintenance	34,328	19,500	(14,828)		(14,828)
6407 Xmas Lights/Trees	24,498	19,000	(5,498)		(5,498)
6408 New Equipment	871	5,500	4,629		4,629
6410 New Equipment	0	2,500	2,500		2,500
6414 Events	12,331	8,000	(4,331)		(4,331)
6417 Maintenance	827	750	(77)		(77)
6418 Defibrillators	1,018	500	(518)		(518)
6420 Litter/Dog Bin Emptying	2,611	2,700	89		89
6440 ROSPA Inspection	675	700	25		25
6455 Agency Staff	191	1,000	809		809
6463 General Maintenance Supplies	117	750	633		633
6469 Pest Control	938	1,500	563		563
6470 War Memorial	114	500	386		386
6471 Skips for cemetery	1,266	700	(566)		(566)
6485 Plants & Sundries	0	2,500	2,500		2,500
6490 Trees/Flower Beds	0	1,000	1,000		1,000
6495 Street Furniture	278	1,500	1,222		1,222
6498 Contingency Fund	0	7,500	7,500		7,500
7100 Travel & Subsistance	46	200	154		154
7300 Staff & Councillors Training	2,956	2,500	(456)		(456)
7410 Service Charges	14	1,445	1,431		1,431
7500 Legal & Professional Fees	22,230	5,000	(17,230)		(17,230)
7510 Audit Fees	2,334	2,500	166		166
7600 Subscriptions	1,996	2,500	504		504
7610 Licences	2,317	3,500	1,183		1,183
7630 Bank Charges	357	300	(57)		(57)
7650 Insurance	11,131	13,115	1,984		1,984
7670 Grants-Voluntary Organisations	15,767	16,500	733		733
7671 Grant Theatre C/N	3,000	3,000	0		0
7672 Grant Lido C/N	5,000	5,000	0		0
7673 Grant Museum	3,500	3,500	0		0
7690 Mayors Allowance	33	1,500	1,467		1,467
7720 Other Miscellaneous Expenses	19,419	1,750	(17,669)		(17,669)
7730 CCTV Contribution	0	2,500	2,500		2,500
7735 HR Retained Service	1,021	2,500	1,479		1,479
7740 Health & Safety Services	2,117	2,500	383		383

Income & Expenditure by Budget 31/03/2026

Month No: 12

Account Code Report

	Actual Year to Date	Current Annual Bud	Budget Variance	Committed Expenditure	Funds Available
Total Overhead	786,778	669,760	(117,018)	0	(117,018)
Total Income	768,692	682,619	(86,073)		
Total Expenditure	786,778	669,760	(117,018)	0	(117,018)
Net Income over Expenditure	(18,086)	12,859	30,945		
plus Transfer from EMR	186,726	0	(186,726)		
less Transfer to EMR	127,983	0	(127,983)		
Movement to/(from) Gen Reserve	40,657	12,859	(27,798)		

31st March 2025

31st March 2026

31st March 2025		31st March 2026	
Current Assets			
188,019	Unity Trust Bank	119,131	
235,000	CCLA Deposit Fund	235,000	
50	Petty Cash	23	
48	Town Hall Float	48	
0	Prepayments	15,544	
7,426	VAT Control	7,591	
1,688	Sundry Debtors	1,217	
24,881	Debtors	47,469	
1,149	Events Stock	1,149	
458,261		427,172	
458,261	Total Assets	427,172	
Current Liabilities			
14,605	Trade Creditors	1,602	
14,605		1,602	
443,656	Total Assets Less Current Liabilities	425,570	
Represented By			
170,815	General Reserves	210,629	
272,841	Earmarked Reserves	214,941	
443,656		425,570	

The above statement represents fairly the financial position of the Authority as at 31/03/2026 and reflects its Income and Expenditure during the year.

Signed :
Chairman

Date : _____

Signed :
Responsible
Financial
Officer

Date : _____

Responsible Financial Officer's Report

Financial Year End Position 2025/26

Members will note that the year-end accounts are presented in a different format from previous finance reports. Since September 2025 finance reports have been in Excel format with additional commentary against individual budget lines to aid understanding. This year end report, has been produced directly from the Council's accounting system. This approach provides a clearer audit trail between the accounting records and the reports presented to Council and audit.

Overall Position

The Income and Expenditure Report shows a net deficit before reserve movements of £18,086 against a budgeted surplus of £12,859, an adverse variance of £30,945.

However, this headline position does not fully reflect the Council's financial performance during the year. Following transfers to and from Earmarked Reserves, year-end accruals and adjustments, the Council's overall financial position was approximately £40,657 better than budgeted, resulting in an increase in General Reserves from £170,815 to £210,629 at 31 March 2026.

The Balance Sheet shows total net assets of £425,570, comprising General Reserves of £210,629 and Earmarked Reserves of £214,941. Cash and investments at year end totalled £354,131.

Income

Members may wish to note the following significant variances:

Rent Receivable finished below budget. The outstanding balance had been fully recovered by year end, with the final payment being received shortly after year end in the 2026/27 financial year.

Lettings Income was below budget. Previous discussions have highlighted that the lettings budget does not adequately reflect the Council's policy of supporting community organisations through discounted and free hall hire. During 2025/26 the Council provided in excess of £30,000 of discounted hire in addition to free hire arrangements, meaning the apparent shortfall broadly reflects an unrealistic income target rather than reduced demand.

Interest Receivable was £10,175 against a budget of £25,000. Following investigation with the previous Responsible Financial Officer, it was confirmed that interest income was only expected to arise from investments and there was no documented rationale for the £25,000 budget figure.

Administration Charges relate primarily to cross-charging arrangements with the William Fowler Allotments Charity and the Welfare Charity. All sums due have been recovered, although part of the income was received in the new financial year.

Miscellaneous Income includes £118,000 received from the Public Works Loan Board borrowing approved to facilitate the establishment of the Council's new in-house Grounds Maintenance Team.

Expenditure

The majority of significant variances relate directly to the in-house Grounds Maintenance Team during the year.

Vehicle Hire (£69,539) and Machinery Hire (£59,361) should more accurately be described as vehicle and machinery acquisition costs.

Similarly, overspends on Tools & Equipment, PPE, fuel and related operational headings reflect the one-off costs of creating a new operational service from scratch.

Legal and Professional Fees exceeded budget due to consultancy support associated with the transfer of grounds maintenance services in-house together with legal costs relating to the acquisition of the depot lease.

Alarm and Fire Extinguisher Inspections were higher than budget as additional contracts and inspections were commissioned to bring Council facilities into compliance with current health and safety requirements.

Other Miscellaneous Expenses totalled £19,419 and comprise a number of non-recurring items including:

- approximately £13,000 relating to the Town Hall Restoration Project, including the CO₂ report and roofing consultancy costs (which were subsequently funded from Earmarked Reserves);
- approximately £3,000 of relocation costs associated with the move from the Guildhall to Glyme Hall; and
- approximately £3,500 relating to health and safety improvements including signage, first aid requirements, welfare provisions, legionella control measures and CCTV improvements.

Reserves

During the year £186,726 was transferred from Earmarked Reserves to fund approved projects and expenditure, whilst £127,983 was transferred into Earmarked Reserves for future commitments.

After all reserve movements, General Reserves increased by £40,657 during the year to £210,629. This represents a stronger outturn than originally budgeted and leaves the Council in a sound financial position going into 2026/27, with adequate reserves and strong cash balances available to support future service delivery and planned projects.



Mrs K Jang
Chipping Norton Town Council
The Guildhall
Chipping Norton
Oxfordshire
OX7 5NJ

26 May 2026

Dear Katherine

Re: Chipping Norton Town Council
Internal Audit Report for Financial Year Ended 31 March 2026

Executive summary

Following completion of our final internal audit on 26 May 2026, we are pleased to enclose our report for your review and presentation to the council. The audit was conducted in accordance with current professional standards and guidelines, employing a risk-based approach to our testing. While not all transactions were examined, our sample testing, where appropriate, covered the financial year to date.

Some assertions, as noted in this report, were tested at the interim internal audit completed during the financial year and the council should review all internal audit reports for the year before completing the Annual Governance Statement.

The structure of this report aligns with the assertions set out in the Annual Internal Auditor Report section of the published Annual Governance and Accountability Return (AGAR). Each section begins with a summary of the assertion being assessed, followed by details of the testing undertaken, which was guided by the audit plan previously shared with the council. A copy of the audit plan is available upon request. The report concludes with our opinion on whether each assertion has been met as of the date of the audit. **Any recommendations for action are highlighted in bold and summarised in the table at the end of the report.**

Our testing did not identify any procedural errors requiring reporting to the external auditor at this time, nor did we observe any material weaknesses in internal controls that would pose a risk to public funds. In fact, the processes and procedures together with own built-in compensating controls are robust, strictly followed and in many respects a model of good practice.

We are pleased to report that overall, the systems and procedures currently in place are appropriate and effective. While this report may include recommendations for improvement, these should not be viewed as indicators of significant deficiencies. Rather, they are intended to support the continued development of what is, in our view, a well-managed and robust governance framework.

I have completed the Annual Internal Audit Report page of the AGAR and provided this to the council for onward submission to the External Auditor.

Regulation

The Accounts and Audit Regulations 2015 require smaller authorities, each financial year, to conduct a review of the effectiveness of the system of internal control and prepare an annual governance statement in accordance with proper practices in relation to accounts. In addition to this, a smaller authority is required by Regulation 5(1) of the Accounts and Audit Regulations 2015 to “undertake an effective internal audit to evaluate the effectiveness of its risk management, control and governance processes, taking into account public sector internal auditing standards or guidance.”

Internal auditing is an independent, objective assurance activity designed to improve an organisation’s operations. It helps an organisation accomplish its objectives by bringing a systematic, disciplined approach to evaluate and improve the effectiveness of risk management, control and governance processes.

The primary purpose of internal audit is to assess and report to the authority on the effectiveness of its financial systems and other internal controls, including the operational procedures that support its activities.

The internal audit function involves testing and evaluating whether the authority’s internal control framework is both adequate and functioning effectively. Internal audit reports should be made available to all Members, providing a basis for informed decision making when considering the authority’s approval of the Annual Governance Statement.

Independence and competence

Your audit was conducted by Andy Beams of Mulberry Local Authority Services Ltd, who has over 36 years’ experience in the financial sector with the last 16 years specialising in local government.

Your auditor is independent from the management of the financial controls and procedures of the council and has no conflicts of interest with the audit client, nor do they provide any management or financial assistance to the client.

Engagement Letter and inherent risk assessment

An engagement letter was previously issued to the council covering the 2025/26 internal audit assignment, which includes the scope and plan of works and fee structure. Copies of this document are available on request from anna@mulberrylas.co.uk

In summary, our work will address each of the internal control objectives as stated on the Annual Internal Audit Report of the AGAR.

It is our opinion that the inherent risk of error or misstatement within the council’s financial systems is low. The internal control environment is considered reliable, and as such, substantive testing of individual transactions is not deemed necessary at this stage.

Audit testing will therefore consist of walk-through testing on a selection of sample data, covering the period under review within the current council year. This approach is designed to confirm that key controls are operating effectively throughout the financial period.

Table of Contents

A. BOOKS OF ACCOUNT	6
B. FINANCE REGULATIONS, GOVERNANCE AND PAYMENTS	6
C. RISK MANAGEMENT AND INSURANCE	6
D. BUDGET, PRECEPT AND RESERVES	7
E. INCOME	8
F. CASH	9
G. PAYROLL	9
H. ASSETS AND INVESTMENTS	9
I. BANK AND CASH	10
J. YEAR END ACCOUNTS	10
K. LIMITED ASSURANCE REVIEW	14
L. PUBLICATION OF INFORMATION	14
M. EXERCISE OF PUBLIC RIGHTS - INSPECTION OF ACCOUNTS	15
N. PUBLICATION REQUIREMENTS	16
O. DIGITAL AND DATA COMPLIANCE	16
P. TRUSTEESHIP	17
Achievement of control assertions at final internal audit date	18
Internal Audit – Summary of recommendations	19

INTRODUCTION

The audit was conducted on site. The information advised in advance of the visit had been prepared and was available for review, and overall, I have the impression that accounting records are neatly maintained and easily accessible.

Other information was reviewed through discussion with the officers and a review of the council website www.chippingnorton-tc.gov.uk

UPDATES ON RECOMMENDATIONS FROM INTERIM AUDIT

Internal Audit – Summary of recommendations

Audit Point	Interim Audit Findings	Council comments
<p>B. FINANCIAL REGULATIONS, GOVERNANCE AND PAYMENTS</p>	<p>An IT Policy needs to be added to the council website before 31 March 2026 to meet the requirements of Governance Assertion 10.</p> <p>I note that the Website Accessibility Statement refers to compliance with Web Content Accessibility Guidelines 2.1AA – the current standard is 2.2AA and the council should confirm with its website provider and update the statement accordingly.</p> <p>Based on the level of financial activity of the council, and through discussion with the officers, these authorisation thresholds appear appropriate although given the financial size of the council, consideration might be given to increasing the thresholds across all levels to facilitate the smooth running of the council.</p> <p>Through discussion with the officers, the above process is not currently being followed, although a dual authentication process does exist involving staff members. I recommend that the council reviews this section of the Financial Regulations and ensures that the process recorded is the one it follows in future.</p>	<p>Tested in Section O of this report.</p> <p>Tested in Section O of this report.</p> <p>The Financial Regulations have been updated and thresholds increased and these will be tested at the next interim audit.</p> <p>The Financial Regulations have been updated and testing for compliance with the amended authentication system will be conducted at the next interim audit.</p>

C. RISK MANAGEMENT AND INSURANCE	The September 2025 bank reconciliations show balances exceeding £640,000 and the council is advised to consider increasing the Fidelity Guarantee level to ensure that the maximum balance held at any point during the year is covered.	The Fidelity Guarantee level has been increased and this will be tested at the next interim audit.
D. BUDGET, PRECEPT AND RESRVES	I note that the Public Art Project EMR shows a negative balance of -£843.12. This figure will need to be cleared from the general reserve by the end of the financial year, as earmarked reserves cannot hold a negative balance.	The EMR balance had been corrected to nil at the final internal audit.
I. BANK AND CASH	I was able to confirm that the bank reconciliations have been signed but there is no evidence that the bank statement have also been signed in accordance with FR 2.6 and I will need to see evidence of this activity taking place at the final internal audit to achieve a positive sign-off for this internal control objective.	At the final internal audit, I was provided with evidence that bank statements are now also being signed as part of the verification process, and the council has met the requirements of this internal control objective.
N. PUBLICATION REQUIREMENTS	The Notice of Conclusion of Audit was not published on the council website until 26 November 2025. The council has therefore not met the publication requirements for 2024/25.	Noted and reflected in response to internal control objective N on the Annual Internal Audit Report.

A. BOOKS OF ACCOUNT

Internal audit requirement

Appropriate accounting records have been kept properly during the year.

Audit findings

Testing conducted at the interim audit and findings included in the interim audit report.

CONCLUSION

I am satisfied this control objective has been met.

B. FINANCE REGULATIONS, GOVERNANCE AND PAYMENTS

Internal audit requirement

This authority complied with its Finance Regulations, payments were supported by invoices, all expenditure was approved, and VAT was appropriately accounted for.

Audit findings

Testing conducted at the interim audit and findings included in the interim audit report. Updates on the recommendations from the interim audit are contained in the table on page 4 of this report.

CONCLUSION

I am satisfied this control objective has been met.

C. RISK MANAGEMENT AND INSURANCE

Internal audit requirement

This authority assessed the significant risks to achieving its objectives and reviewed the adequacy of arrangements to manage these.

Audit findings

Testing conducted at the interim audit and findings included in the interim audit report. Updates on the recommendations from the interim audit are contained in the table on page 4 of this report.

We discussed assertion 8 on the Annual Governance Statement and whether this had any impact on the council.

“We considered whether any litigation, liabilities or commitments, events or transactions, occurring either during or after the year-end, have a financial impact on this authority and, where appropriate, have included them in the accounting statements.”

The officers confirmed that they were not aware of any event having a financial impact that was not included in the accounting statements.

CONCLUSION

I am satisfied this control objective has been met.

D. BUDGET, PRECEPT AND RESERVES

Internal audit requirement

The precept or rates requirement resulted from an adequate budgetary process; progress against the budget was regularly monitored; and reserves were appropriate.

Audit findings

Testing conducted at the interim audit and findings included in the interim audit report. Updates on the recommendations from the interim audit are contained in the table on page 4 of this report.

Budget

Regular detailed budget reports are produced from the accounting software. The year-end budget report shows income reported as 113% of budget and expenditure at 118% prior to any reserve adjustments. There is no evidence to suggest that the budget has not been accurately set and carefully monitored throughout the year.

There is evidence within the minutes of meetings that councillors regularly receive budget reports for review, providing them with sufficient financial information to make informed decisions.

Precept

The council set a precept of £494,204 for 2025/26. With a tax base of 2,898.39, this equates to a band D equivalent of £170.51 (compared to the average in England of £92.92).

I was able to confirm that the precept amount recorded in the accounts is correct, and equals the amount recorded in box 2 of the Accounting Statements.

I confirmed from the minutes that the 2026/27 budget and precept were approved by the council at the meeting held on 8 December 2025 (minute refs FC107 and FC108 respectively).

Reserves

The Smaller Authorities Proper Practices Panel (SAPPP) Practitioner's guide provides updated guidance on the appropriate level of general reserves that councils should retain as below:

5.33 The general reserve of an authority comprises its cash flow and contingency funds to cover unexpected inflation, unforeseen events and unusual circumstances.

5.34 The generally accepted recommendation with regard to the appropriate minimum level of a smaller authority's general reserve is that this should be maintained at between three and twelve months of net revenue expenditure.

5.35 The reason for the wide range is to cater for the large variation in activity level between individual authorities. The smaller the authority, the closer the figure may be to 12 months expenditure, the larger the

authority, the nearer to 3 months. In practice, any authority with income and expenditure in excess of £200,000 should plan towards 3 months equivalent general reserve.

5.36 In all of this it is important that each authority adopt, as a general reserve policy, the level appropriate to their size, situation, risks and plan their budget so as to ensure that the adopted level is maintained. Consideration of the minimum level of reserves requires not only consideration of level of income and expenditure but also the risks to that income.

5.37 Authorities with significant self-generated income (other than the precept or levy) should take into account situations that may lead to a loss in revenue as well as increased costs and adapt their general reserve accordingly.

At the year-end, the council held circa £425,570 in reserves, split between categories as below:

- Earmarked Reserves £214,941
- General Reserves £210,629

I checked the purpose of these earmarked reserves and am satisfied they are all for legitimate future planned projects of the council.

The general reserve balance is which is within the recommended range as detailed in the Practitioner's Guide.

CONCLUSION

I am satisfied this control objective has been met.

E. INCOME

Internal audit requirement

Expected income was fully received, based on correct prices, properly recorded and promptly banked; and VAT was appropriately accounted for.

Audit findings

Testing conducted at the interim audit and findings included in the interim audit report.

CONCLUSION

I am satisfied this control objective has been met.

F. CASH

Internal audit requirement

Cash payments were properly supported by receipts; all cash expenditure was approved and VAT appropriately accounted for.

Audit findings

Testing conducted at the interim audit and findings included in the interim audit report.

CONCLUSION

I am satisfied this control objective has been met.

G. PAYROLL

Internal audit requirement

Salaries to employees and allowances to members were paid in accordance with the authority's approvals, and PAYE and NI requirements were properly applied.

Audit findings

Testing conducted at the interim audit and findings included in the interim audit report.

I reviewed the figure included in box 4 (staff costs) on the Accounting Statements and was able to confirm from the accounting software that in accordance with the guidance contained in the Smaller Authorities Proper Practices Panel (SAPPP) Practitioner's guide this includes only salary payments, HMRC payments and pension contributions.

CONCLUSION

I am satisfied this control objective has been met.

H. ASSETS AND INVESTMENTS

Internal audit requirement

Asset and investments registers were complete and accurate and properly maintained.

Audit findings

Testing conducted at the interim audit and findings included in the interim audit report.

I confirmed the asset register total matches that included in box 9 (total fixed assets plus long term investments and assets) on the Accounting Statements. There have been no additions nor deletions during the year.

The council has borrowing through the Public Works Loan Board (PWLB) and I was able to confirm the figures for in year payments (box 5) and year-end balance (box 10) on the Accounting Statements against the PWLB remittance advices and year-end statement.

CONCLUSION

I am satisfied this control objective has been met.

I. BANK AND CASH

Internal audit requirement

Periodic bank account reconciliations were properly carried out during the year.

Audit findings

Testing conducted at the interim audit and findings included in the interim audit report. Updates on the recommendations from the interim audit are contained in the table on page 4 of this report.

I reviewed the year-end bank reconciliation for all accounts and was able to confirm the balances on 31 March 2026 to the bank statements and found no errors. I was able to confirm the total bank balances to the figure included in the Accountings Statements on the AGAR.

CONCLUSION

I am satisfied this control objective has been met.

J. YEAR END ACCOUNTS

Internal audit requirement

Accounting statements prepared during the year were prepared on the correct accounting basis (receipts and payments or income and expenditure), supported by an adequate audit trail from underlying records and, where appropriate, debtors and creditors were properly recorded.

Audit findings

The council is reminded that at its meeting to sign the Annual Governance and Accountability Return (AGAR), it should complete the steps in the following order:

- **Review and consider the Annual Internal Audit Report**
- **Complete Section 1 – Annual Governance Statement**
- **Complete Section 2 – Accounting Statements**

Section 1 – Annual Governance Statement

Based on the internal audit findings, I recommend using the table below as the basis for that discussion.

	Annual Governance Statement	<i>'Yes', means that this authority</i>	Suggested response based on evidence
1	We have put in place arrangements for effective financial management during the year, and for the preparation of the accounting statements.	<i>prepared its accounting statements in accordance with the Accounts and Audit Regulations.</i>	YES – accounts follow latest Accounts and Audit Regulations and practitioners guide recommendations.
2	We maintained an adequate system of internal control including measures designed to prevent and detect fraud and corruption and reviewed its effectiveness.	<i>made proper arrangements and accepted responsibility for safeguarding the public money and resources in its charge.</i>	YES – there is regular reporting of financial transactions and accounting summaries, offering the opportunity for scrutiny.
3	We have assured ourselves that there are no matters of actual or potential non-compliance with laws, regulations and Proper Practices that could have a significant financial effect on the ability of this authority to conduct its business or manage its finances.	<i>has only done what it has the legal power to do and has complied with Proper Practices in doing so.</i>	YES – the Clerk advises the council in respect of its legal powers.
4	We provided proper opportunity during the year for the exercise of electors' rights in accordance with the requirements of the Accounts and Audit Regulations.	<i>during the year gave all persons interested the opportunity to inspect and ask questions about this authority's accounts.</i>	YES – the requirements and timescales for 2024/25 year-end were followed.
5	We carried out an assessment of the risks facing this authority and took appropriate steps to manage those risks, including the introduction of internal controls and/or external insurance cover where required.	<i>considered and documented the financial and other risks it faces and dealt with them properly.</i>	YES – the council has a risk management scheme and appropriate external insurance.
6	We maintained throughout the year an adequate and effective system of internal audit of the accounting records and control systems.	<i>arranged for a competent person, independent of the financial controls and procedures, to give an objective view on whether internal controls meet the needs of this smaller authority.</i>	YES – the council has appointed an independent and competent internal auditor.
7	We took appropriate action on all matters raised in reports from internal and external audit.	<i>responded to matters brought to its attention by internal and external audit.</i>	YES – matters raised in internal and external audit reports have been addressed.

8	We considered whether any litigation, liabilities or commitments, events or transactions, occurring either during or after the year-end, have a financial impact on this authority and. Where appropriate, have included them in the accounting statements.	<i>disclosed everything it should have about its business activity during the year including events taking place after the year end if relevant.</i>	YES – no matters were raised during the internal audit visits.
9	Trust funds including charitable – In our capacity as the sole managing trustee we discharged our accountability responsibilities for the fund(s)/asset(s), including financial reporting and, if required, independent examination or audit.	<i>has met all its responsibilities where, as a body corporate, it is a sole managing trustee of a local trust or trusts.</i>	N/A – the council has no trusts
10	We have put in place arrangements for the effective IT and data management in accordance with proper practices during the year under review.	<i>has made suitable arrangements for its IT and data management and has complied with proper practices in doing so</i>	YES – the council has met the requirements of Governance Assertion 10

Section 2 – Accounting Statements

AGAR box number		2024/25	2025/26	Internal Auditor notes
1	Balances brought forward	482,163	443,656	Agrees to 2024/25 carry forward (box 7)
2	Precept or rates and levies	375,832	494,204	Figure confirmed to central precept record
3	Total other receipts	166,081	274,488	Agrees to underlying accounting records
4	Staff costs	250,476	335,215	Agrees to underlying accounting records. Includes only expenditure allowed as staff costs (see section G)
5	Loan interest/capital repayments	0	7,613	Agrees to PWLB remittance advices
6	All other payments	329,944	443,950	Agrees to underlying accounting records
7	Balances carried forward	443,656	425,570	Casts correctly and agrees to balance sheet
Total				
8	Total value of cash and short- term investments	423,117	354,202	Agrees to bank reconciliation for all accounts
9	Total fixed assets plus long- term investments and assets	4,247,030	4,247,030	Matches asset register total
10	Total borrowings	0	114,193	Agrees to PWLB statement
Total				
11	Do the figures in the accounting statements above exclude any trust transactions	Yes	Yes	Yes – trust transactions are excluded from the stated figures

Audit findings

The year-end accounts have been correctly prepared on an income and expenditure basis with the box 7 and 8 reconciliation completed. This shows total year-end debtors of £72,670 and total year-end creditors of £1,602, with a full breakdown of the individual debtors and creditors provided.

The AGAR correctly casts and cross casts and last year's comparatives match the figures submitted for 2024/25 and published on the council website.

The variance analysis has been completed and, in my opinion, provides sufficient financial and narrative information to explain the variances to the External Auditor.

CONCLUSION

I am satisfied this control objective has been met.

K. LIMITED ASSURANCE REVIEW

Internal audit requirement

If the authority certified itself as exempt from a limited assurance review in the previous year, it met the exemption criteria and correctly declared itself exempt.

CONCLUSION

The council did not certify itself exempt from a limited assurance review in the previous year and the testing for this internal control objective is not applicable.

L: PUBLICATION OF INFORMATION

Internal audit requirement

The authority publishes information on a free to access website/webpage, up to date at the time of the internal audit in accordance with relevant legislation

Audit findings

All councils are required to follow The Accounts and Audit Regulations which include the following requirements:

- 13(1)** An authority must publish (which must include publication on that authority's website)
- (a) the Statement of Accounts together with any certificate or opinion entered by the local auditor in accordance with section 20(2) of the Act; and
 - (b) the Annual Governance Statement approved in accordance with regulation 6(3)
- 13(2)** Where documents are published under paragraph (1), the authority must
- (a) keep copies of those documents for purchase by any person on payment of a reasonable sum; and
 - (b) ensure that those documents remain available for public access for a period of not less than five years beginning with the date on which those documents were first published in accordance with that paragraph.

I was able to confirm that pages 4 (Annual Governance Statement), 5 (Accounting Statements) and 6 (External Auditor's Report and Certificate) of the AGARs are available for review on the council website for the previous five financial years.

Confirm that the council is compliant with the relevant transparency code

For councils with a turnover over £25,000, it is recommended best practice to follow the Local Government Transparency Code 2015, but not a statutory requirement and therefore not subject to verification during the internal audit.

CONCLUSION

I am satisfied this control objective has been met.

M: EXERCISE OF PUBLIC RIGHTS - INSPECTION OF ACCOUNTS

Internal audit requirement

The authority, during the previous year, correctly provided for the exercise of public rights as required by the Accounts and Audit Regulations.

Audit findings

Inspection – key dates	2024/25 Actual	2025/26 Proposed
Date AGAR signed by council	9 June 2025	8 June 2026
Date inspection notice issued	10 June 2025	9 June 2026
Inspection period begins	11 June 2025	10 June 2026
Inspection period ends	22 July 2025	21 July 2026
Correct length (30 working days)	Yes	Yes
Common period included (first 10 working days of July)	Yes	Yes

I am satisfied the requirements of this control objective were met for 2024/25, and assertion 4 on the Annual Governance Statement can therefore be signed yes by the council.

I reviewed the proposed dates for the Exercise of Public Rights for the 2025/26 AGAR and confirm that these are in accordance with the requirements of the Accounts and Audit Regulations.

CONCLUSION

I am satisfied this control objective has been met.

N: PUBLICATION REQUIREMENTS

Internal audit requirement

The authority complied with the publication requirements for the prior year AGAR.

Under the Accounts and Audit Regulations 2015, authorities must publish the following information on the authority website / webpage.

Before 1 July 2025 authorities must publish:

- *Notice of the period for the exercise of public rights and a declaration that the accounting statements are as yet unaudited*
- *Section 1 - Annual Governance Statement 2024/25, approved and signed, page 4*
- *Section 2 - Accounting Statements 2024/25, approved and signed, page 5*

Not later than 30 September 2025 authorities must publish:

- *Notice of conclusion of audit*
- *Section 3 - External Auditor Report and Certificate*
- *Sections 1 and 2 of AGAR including any amendments as a result of the limited assurance review.*

It is recommended as best practice, to avoid any potential confusion by local electors and interested parties, that you also publish the Annual Internal Audit Report, page 3.

Audit findings

Testing conducted at the interim audit and findings included in the interim audit report. **As noted at the time, the Notice of Conclusion of Audit was not published on the council website until 26 November 2025, and the council has therefore not met the publication requirements for 2024/25.**

CONCLUSION

I am not satisfied this control object has been met. Please see the comments above and our recommended course of action in the table at the end of this report.

O. DIGITAL AND DATA COMPLIANCE

Internal audit requirement

The authority has complied with laws, regulations and proper practices relating to digital and data compliance.

Audit findings

The Smaller Authorities Proper Practices Panel (SAPPP) Practitioner's Guide (March 2025) contains guidance on the new Governance Assertion included on the 2025/26 AGAR which relates to this internal control objective.

Website

I was able to confirm that the council website contains a Privacy Notice and a Website Accessibility Statement. The Website Accessibility Statement correctly references partial compliance with the Web Content Accessibility Guidelines (WCAG) 2.2 AA.

The council has an IT Policy in place which was last reviewed and approved by the council at the meeting held on 9 February 2026 (minute ref FC131).

Email management and GDPR

It was noted the council has a generic email address on a domain owned by the council and has established common email addresses for all councillors. This is recommended because it gives a natural segregation between work and personal lives, making it clear beyond doubt in what capacity a councillor is acting. In addition to this it gives control to the council, adds a degree of professionalism and in the event of a FOI request limits access to personal computers.

I recommend the council ensures that a data audit is completed during 2026/27 to comply with GDPR regulations. This may be included within the audit testing for Governance Assertion 10 in future years.

CONCLUSION

I am satisfied this control objective has been met.

P. TRUSTEESHIP

Internal audit requirement

Trust funds (including charitable) – The council met its responsibilities as a trustee.

CONCLUSION

The council has no trusts and the testing for this internal control objective is not applicable.

Achievement of control assertions at final internal audit date

Based on the tests conducted during the interim audit, our conclusions on the achievement of the internal control objectives to date are summarised in the table below.

	INTERNAL CONTROL OBJECTIVE	YES	NO	NOT COVERED
A	Appropriate accounting records have been properly kept throughout the financial year	✓		
B	This authority complied with its Finance Regulations, payments were supported by invoices, all expenditure was approved, and VAT was appropriately accounted for	✓		
C	This authority assesses the significant risks to achieving its objectives and reviewed the adequacy of arrangements to manage these	✓		
D	The precept or rates requirement resulted from an adequate budgetary process; progress against the budget was regularly monitored; and reserves were appropriate.	✓		
E	Expected income was fully received, based on correct prices, properly recorded and promptly banked; and VAT was appropriately accounted for	✓		
F	Cash payments were properly supported by receipts, all cash expenditure was approved, and VAT appropriately accounted for	✓		
G	Salaries to employees and allowances to members were paid in accordance with the authority's approvals, and PAYE and NI requirements were properly applied.	✓		
H	Asset and investments registers were complete and accurate and properly maintained.	✓		
I	Periodic bank account reconciliations were properly carried out during the year.	✓		
J	Accounting statements prepared during the year were prepared on the correct accounting basis (receipts and payments or income and expenditure), supported by an adequate audit trail from underlying records and, where appropriate, debtors and creditors were properly recorded.	✓		
K	If the authority certified itself as exempt from a limited assurance review in the previous year, it met the exemption criteria and correctly declared itself exempt.			✓
L	The authority publishes information on a free to access website/webpage up to date at the time of the internal audit in accordance with the relevant legislation.	✓		
M	The authority, during the previous year correctly provided for the period for the exercise of public rights as required by the Accounts and Audit Regulations.	✓		
N	The authority complied with the publication requirements for prior year AGAR.		✓	
O	The authority has complied with laws, regulations and proper practices relating to digital and data compliance	✓		
P	Trust funds (including charitable) – The council met its responsibilities as a trustee.			✓

Should you have any queries please contact me directly at andy@mulberrylas.co.uk

Yours sincerely



Andy Beams

Director, Mulberry Local Authority Services Ltd

Internal Audit – Summary of recommendations

Audit Point	Internal Audit Findings	Council comments
O. DIGITAL AND DATA COMPLIANCE	I recommend the council ensures that a data audit is completed during 2026/27 to comply with GDPR regulations. This may be included within the audit testing for Governance Assertion 10 in future years.	

Annual Internal Audit Report 2025/26

Chipping Norton Town Council

<https://www.chippingnorton-tc.gov.uk/town-council/> EBSITE/WEBPAGE ADDRESS

During the financial year ended 31 March 2026, this authority's internal auditor acting independently and on the basis of an assessment of risk, carried out a selective assessment of compliance with the relevant procedures and controls in operation and obtained appropriate evidence from the authority.

The internal audit for 2025/26 has been carried out in accordance with this authority's needs and planned coverage. On the basis of the findings in the areas examined, the internal audit conclusions are summarised in this table. Set out below are the objectives of internal control and alongside are the internal audit conclusions on whether, in all significant respects, the control objectives were being achieved throughout the financial year to a standard adequate to meet the needs of this authority.

Internal control objective	Yes	No*	Not covered**
A. Appropriate accounting records have been properly kept throughout the financial year.	✓		
B. This authority complied with its financial regulations, payments were supported by invoices, all expenditure was approved and VAT was appropriately accounted for.	✓		
C. This authority assessed the significant risks to achieving its objectives and reviewed the adequacy of arrangements to manage these.	✓		
D. The precept or rates requirement resulted from an adequate budgetary process; progress against the budget was regularly monitored; and reserves were appropriate.	✓		
E. Expected income was fully received, based on correct prices, properly recorded and promptly banked; and VAT was appropriately accounted for.	✓		
F. Cash payments were properly supported by receipts, all cash expenditure was approved and VAT appropriately accounted for.	✓		
G. Salaries to employees and allowances to members were paid in accordance with this authority's approvals, and PAYE and NI requirements were properly applied.	✓		
H. Asset and investments registers were complete and accurate and properly maintained.	✓		
I. Periodic bank account reconciliations were properly carried out during the year.	✓		
J. Accounting statements prepared during the year were prepared on the correct accounting basis (receipts and payments or income and expenditure), agreed to the cash book, supported by an adequate audit trail from underlying records and where appropriate debtors and creditors were properly recorded.	✓		
K. If the authority certified itself as exempt from a limited assurance review in 2024/25, it met the exemption criteria and correctly declared itself exempt. (If the authority had a limited assurance review of its 2024/25 AGAR tick "not covered")			✓
L. The authority published the required information on a website/webpage up to date at the time of the internal audit in accordance with the relevant legislation.	✓		
M. In the year covered by this AGAR, the authority correctly provided for a period for the exercise of public rights as required by the Accounts and Audit Regulations (during the 2025/26 AGAR period, were public rights in relation to the 2024-25 AGAR evidenced by a notice on the website and/or authority approved minutes confirming the dates set).	✓		
N. The authority has complied with the publication requirements for 2024/25 AGAR (see AGAR Page 1 Guidance Notes).		✓	
O. The authority has complied with laws, regulations & proper practices relating to digital and data compliance.	✓		
P. (For local councils only) Trust funds (including charitable) – The council met its responsibilities as a trustee.			✓

For any other risk areas identified by this authority adequate controls existed (list any other risk areas on separate sheets if needed).

Date(s) internal audit undertaken

Name of person who carried out the internal audit

28/11/2025

26/05/2026

DD/MM/YYYY

A Beams Mulberry LAS Ltd INTERNAL AUDITOR

Signature of person who carried out the internal audit



Date

26/05/2026

*If the response is 'no' please state the implications and action being taken to address any weakness in control identified (add separate sheets if needed).

**Note: If the response is 'not covered' please state when the most recent internal audit work was done in this area and when it is next planned; or, if coverage is not required, the annual internal audit report must explain why not (add separate sheets if needed).

Section 1 – Annual Governance Statement 2025/26

We acknowledge as the members of:

Chipping Norton Town Council

our responsibility for ensuring that there is a sound system of internal control, including arrangements for the preparation of the Accounting Statements. We confirm, to the best of our knowledge and belief, with respect to the Accounting Statements for the year ended 31 March 2026, that:

	Agreed		'Yes' means that this authority:
	Yes	No*	
1. We have put in place arrangements for effective financial management during the year, and for the preparation of the accounting statements.	✓		<i>prepared its accounting statements in accordance with the Accounts and Audit Regulations.</i>
2. We maintained an adequate system of internal control including measures designed to prevent and detect fraud and corruption and reviewed its effectiveness.	✓		<i>made proper arrangements and accepted responsibility for safeguarding the public money and resources in its charge.</i>
3. We have assured ourselves that there are no matters of actual or potential non-compliance with laws, regulations and Proper Practices that could have a significant financial effect on the ability of this authority to conduct its business or manage its finances.	✓		<i>has only done what it has the legal power to do and has complied with Proper Practices in doing so.</i>
4. We provided proper opportunity during the year for the exercise of electors' rights in accordance with the requirements of the Accounts and Audit Regulations.	✓		<i>during the year gave all persons interested the opportunity to inspect and ask questions about this authority's accounts.</i>
5. We carried out an assessment of the risks facing this authority and took appropriate steps to manage those risks, including the introduction of internal controls and/or external insurance cover where required.	✓		<i>considered and documented the financial and other risks it faces and dealt with them properly.</i>
6. We maintained throughout the year an adequate and effective system of internal audit of the accounting records and control systems.	✓		<i>arranged for a competent person, independent of the financial controls and procedures, to give an objective view on whether internal controls meet the needs of this smaller authority.</i>
7. We took appropriate action on all matters raised in reports from internal and external audit.	✓		<i>responded to matters brought to its attention by internal and external audit.</i>
8. We considered whether any litigation, liabilities or commitments, events or transactions, occurring either during or after the year-end, have a financial impact on this authority and, where appropriate, have included them in the accounting statements.	✓		<i>disclosed everything it should have about its business activity during the year including events taking place after the year end if relevant.</i>
9. (For local councils only) Trust funds including charitable. In our capacity as the sole managing trustee we discharged our accountability responsibilities for the fund(s)/assets, including financial reporting and, if required, independent examination or audit.	Yes	No	N/A
			✓
10. We have put in place arrangements for the effective IT and data management in accordance with proper practices during the year under review.	✓		<i>has made suitable arrangements for its IT and data management and has complied with proper practices in doing so.</i>

*Please provide explanations to the external auditor on a separate sheet for each 'No' response and describe how the authority will address the weaknesses identified. These sheets must be published with the Annual Governance Statement.

This Annual Governance Statement was approved at a meeting of the authority on:

08/06/2026

and recorded as minute reference:

MINUTE REFERENCE

Signed by the Chair and Clerk of the meeting where approval was given:

Chair

SIGNATURE REQUIRED

Clerk

SIGNATURE REQUIRED

<https://www.chippingnorton-tc.gov.uk/town-council/>

Section 2 – Accounting Statements 2025/26 for

Chipping Norton Town Council

	Year ending		Notes and guidance
	31 March 2025 £	31 March 2026 £	
1. Balances brought forward	482,163	443,656	Total balances and reserves at the beginning of the year as recorded in the financial records. Value must agree to Box 7 of previous year.
2. (+) Precept or Rates and Levies	375,832	494,204	Total amount of precept (or for IDBs rates and levies) received or receivable in the year. Exclude any grants received.
3. (+) Total other receipts	166,081	274,488	Total income or receipts as recorded in the cashbook less the precept or rates/levies received (line 2). Include any grants received.
4. (-) Staff costs	250,476	335,215	Total expenditure or payments made to and on behalf of all employees. Include gross salaries and wages, employers NI contributions, employers pension contributions, gratuities and severance payments.
5. (-) Loan interest/capital repayments	0	7,613	Total expenditure or payments of capital and interest made during the year on the authority's borrowings (if any).
6. (-) All other payments	329,944	443,950	Total expenditure or payments as recorded in the cashbook less staff costs (line 4) and loan interest/capital repayments (line 5).
7. (=) Balances carried forward	443,656	425,570	Total balances and reserves at the end of the year. must equal (1+2+3) - (4+5+6).
8. Total value of cash and short term investments	423,117	354,202	The sum of all current and deposit bank accounts, cash holdings and short term investments held as at 31 March – To agree with bank reconciliation.
9. Total fixed assets plus long term investments and assets	4,247,030	4,247,030	The value of all the property the authority owns – it is made up of all its fixed assets and long term investments as at 31 March.
10. Total borrowings		114,193	The outstanding capital balance as at 31 March of all loans from third parties (including PWLB).

For Local Councils Only	Yes	No	
11 Do the figures in the accounting statements above exclude any trust transactions?	✓		For guidance refer to the Practitioners' Guide sections 2.31 to 2.33.

I certify that for the year ended 31 March 2026 the Accounting Statements in this Annual Governance and Accountability Return have been prepared on either a receipts and payments or income and expenditure basis following the guidance in Governance and Accountability for Smaller Authorities – a Practitioners' Guide to Proper Practices and present fairly the financial position of this authority.

Signed by Responsible Financial Officer before being presented to the authority for approval.



Date 03/06/2026

I confirm that these Accounting Statements were approved by this authority on this date:

08/06/2026

as recorded in minute reference:

MINUTE REFERENCE

Signed by Chair of the meeting where the Accounting Statements were approved

SIGNATURE REQUIRED

Chipping Norton Town Council

NOTICE OF PUBLIC RIGHTS AND PUBLICATION OF UNAUDITED ANNUAL GOVERNANCE & ACCOUNTABILITY RETURN

ACCOUNTS FOR THE YEAR ENDED 31 MARCH 2026

Local Audit and Accountability Act 2014 Sections 26 and 27
The Accounts and Audit Regulations 2015 (SI 2015/234)

NOTICE

1. Date of announcement Tuesday 9th June 2026

2. Each year the smaller authority's Annual Governance and Accountability Return (AGAR) needs to be reviewed by an external auditor appointed by Smaller Authorities' Audit Appointments Ltd. The unaudited AGAR has been published with this notice. As it has yet to be reviewed by the appointed auditor, it is subject to change as a result of that review.

Any person interested has the right to inspect and make copies of the accounting records for the financial year to which the audit relates and all books, deeds, contracts, bills, vouchers, receipts and other documents relating to those records must be made available for inspection by any person interested. For the year ended 31 March 2026, these documents will be available on reasonable notice by application to:

Louise Warren
Responsible Finance Officer & Deputy Clerk
Glyme Hall
Burford Road
OX7 5DZ

Tel: 01608 642341

Email: finance@chippingnorton-tc.gov.uk

commencing on Wednesday 10th June 2026

and ending on Tuesday 21st July 2026

3. Local government electors and their representatives also have:

- The opportunity to question the appointed auditor about the accounting records; and
- The right to make an objection which concerns a matter in respect of which the appointed auditor could either make a public interest report or apply to the court for a declaration that an item of account is unlawful. Written notice of an objection must first be given to the auditor and a copy sent to the smaller authority.

The appointed auditor can be contacted at the address in paragraph 4 below for this purpose between the above dates only.

4. The smaller authority's AGAR is subject to review by the appointed auditor under the provisions of the Local Audit and Accountability Act 2014, the Accounts and Audit Regulations 2015 and the NAO's Code of Audit Practice 2015. The appointed auditor is:

Moore East Midlands (Ref AP/HD)
Rutland House
Minerva Business Park
Lynch Wood
Peterborough
PE2 6PZ



5. This announcement is made by Louise Warren, Responsible Finance Officer & Deputy Town Clerk.

LOCAL AUTHORITY ACCOUNTS: A SUMMARY OF YOUR RIGHTS

Please note that this summary applies to all relevant smaller authorities, including local councils, internal drainage boards and 'other' smaller authorities.

The basic position

By law, any interested person has the right to inspect the accounting records of smaller authorities. If you are a local government elector or registered to vote in the local councils' elections, then you are able to ask questions about the accounts and object to them.

The right to inspect the accounting records

When your council has finalised its accounts for the previous financial year, they must advertise that they are available for people to inspect. You must then provide the council with reasonable notice of your intentions. Following this, by arrangement you will then have 30 working days to inspect and make copies of the accounting records and supporting documents. You may be required to pay a copying charge.

The right to ask the auditor questions about the accounting records

If you have any questions regarding the accounting records, you should first ask your smaller authority. This must be done during the 30-day period for the exercise of public rights. You may also ask the appointed auditor questions about an item in the accounting records. However, the auditor can only answer 'what' questions, not 'why' questions so is limited with their response. To avoid any confusion, it is advised that you put your questions in writing.

The right to make objections

Should you view something as unlawful or believe there are matters of wider concern in the accounts, you may wish to object. If you are a local government elector, you have the right to ask the external auditor to apply to the courts for a declaration that an item is contrary to the law and should be reported as a matter of public interest. This must be done by telling the appointed auditor which specific item in the accounts you object to and why you believe it to be unlawful or think a public interest report should be made about it. You must provide clear evidence to support your objection, and this should be done in writing and the copied to the council.

You should not use the 'right to object' to make a personal complaint or claim against your smaller authority. Complaints of this nature should be taken to your local Citizens' Advice Bureau, local Law Centre or to your solicitor.

A final word

Smaller authorities, and so local taxpayers, meet the costs of dealing with questions and objections. In deciding whether to take your objection forward, the auditor must consider the cost that will be involved. They will only continue with the objection if it is in the public interest to do so. If you appeal to the courts against an auditor's decision, you may have to pay for the action yourself.

Andy's Man Club

From [REDACTED] >
Date Fri 2026-05-08 15:23
To Katherine Jang <townclerk@chippingnorton tc.gov.uk>

Chipping Norton Town Council

Warning: Sender [REDACTED] has never sent any emails to your organization. Please be careful before replying or clicking on the URLs.

[Report Phishing](#) [Remove Banner](#)

powered by Graphus®

You don't often get email from jeremymstone@hotmail.co.uk. [Learn why this is important](#)

Hi Katherine

Great to briefly chat yesterday about Andy's Man Club. As promised please see below the website which gives the details about how the clubs run. The requirement for the space needed is very straightforward, no access to alcohol but with access to tea and coffee making. The groups are non political and non religious so that needs to be reflected too. The club runs every Monday evening from 7.00pm to 9.00pm except for Bank Holidays.

I suspect that it will take a few months to set up in CN. I will obviously be a facilitator and we will need 3-4 others I suspect. I have a few ideas of others who could facilitate but if you have any thoughts please do let me know.

Please also let me know if you think the Town Council can help provide the space to run the club.

Many thanks and see you soon.

Jez



It's Okay To Talk
andysmanclub.co.uk

Sent from my iPad

Proposal for Use of the Oak Room – 14 July

On behalf of **Linda Aspey from People Planet Pint**, we request **free use of the Oak Room at Glyme Hall on 14 July from 17:00–22:00** to host a community screening of the film *National Emergency Briefing* followed by a group discussion.

About the film: *National Emergency Briefing* is a 45–50 minute public-information film featuring leading UK climate and nature experts. It clearly explains the national climate and nature emergency and encourages informed community discussion.

16c. Chipping Norton Improvement Survey

Launched by MP Sean Woodcock, *“As the MP for Banbury, Chipping Norton, Charlbury and the North Oxfordshire villages, I want to ensure that the voices of Chipping Norton residents shape the future of the town. This survey is an opportunity for you to share what improvements matter most to you, your family, and your community. Your views will help guide my work with local authorities and partners to secure positive change for Chipping Norton.*

Names and addresses will be collected to ensure the survey is being filled out by the intended people, and is only used by those within the constituency due to Parliamentary rules. If any issues are flagged, you may receive follow-up emails to provide support. Data will be stored internally, and will not be shared with any third party.”

Link: https://docs.google.com/forms/d/e/1FAIpQLSdZrFPP7Tp4eX1X0Bze-3XzdggnawlDXjU6iiH3ppS_MUrqA/viewform

This report is to note only

16d. Renewable energy payments

Oxfordshire's communities can benefit from the renewable energy projects currently progressing through the planning system. We are writing to invite your Parish Council to take part in a public consultation on a new policy that could put long-term, locally controlled funding directly into your community's hands. The draft Interim Policy for Community Benefit Contributions and Community Shared Ownership is now open for public consultation on Let's Talk Oxfordshire.

👉 Respond here: [Let's Talk Oxfordshire – CBC/CSO Consultation](#)

WHAT THIS COULD MEAN FOR YOUR PARISH

- For host communities of renewable energy projects, annual payments to your community, index-linked from the developer to a local fund for the full operational life of the project, potentially 20 to 40 years.
- For renewable energy projects under 10 MW, 100% of the community benefit contribution stays in the local fund. It comes directly to communities like yours.
- Decisions on how to spend the Local Fund will be made by you, guided by a Community Action Plan developed with and for your community.
- The pipeline is already here. There are over 25 projects in the Oxfordshire planning system and this pipeline could generate contracts for over £20 million in community benefit contributions by 2030. This policy ensures your community gets its fair share.

AN IMPORTANT POINT ON PLANNING

This policy does not determine whether renewable energy projects get built – that is entirely a matter for the planning system. What this policy does is ensure that if a project is approved, your community is treated fairly and consistently. We cannot control what comes forward – but we can make sure Oxfordshire communities get the best out of it.

HOW TO TAKE PART

We encourage your Parish Council to submit a formal response to the consultation, and we invite individual councilors to respond in their own right too. The consultation closes Monday 15th June 2026. For queries, please contact climate.action@oxfordshire.gov.uk

Regards

Mark Saunders

Energy Systems and Investment Manager, Oxfordshire County Council

The Town Clerk has followed up with Mark Saunders and has received confirmation that there are no projects being considered which would affect Chipping Norton Town Council. There is a database and map which can be accessed via the following links:

<https://www.gov.uk/government/publications/renewable-energy-planning-database-quarterly-extract>

<https://data.barbour-abi.com/smart-map/repd/desnz/?type=repd>

RECOMMENDATION: That the Council considers a formal response to the survey regarding the draft Policy for Community Benefit Contributions and Community Shared Ownership.

16e. Chipping Norton Age Concern's Charitable Objects

Notice to change Charitable Objects Following the closure in 2022 of 'Highlands', Age Concern Chipping Norton's Day Centre on the Burford Road, Trustees have recently been in discussion with The Theatre Chipping Norton to run an exciting programme of activities up at Highlands. The Trustees are in the process of submitting an application to the Charity Commission to update and widen Age Concern Chipping Norton's charitable objects to reflect the changing needs and situations of those the charity serves. This is to enable more appropriate provision for the community, that better reflects its wants and needs. As part of the application to the Charity Commission, we are consulting the local community, especially our key beneficiaries, older people and the disabled, on the proposed new wording for our charitable objects. Please read the following information carefully and email Trustees at chippyageconcern@hotmail.com with any views or comments:

Current Charity Name: Age Concern Chipping Norton Area Day Centre

Current Charitable Objects: The object of the organisation shall be to promote the welfare of disabled and elderly people in Chipping Norton and the surrounding area.

Proposed new name: **Age Concern Chipping Norton**

Proposed new Charitable Objects: The objects of the organisation are, for the benefit of the public, to promote the welfare and improve the conditions of life of the inhabitants, in particular (but not exclusively) the elderly and the disabled, of Chipping Norton and the surrounding area, including (but not exclusively): through the provision of facilities for recreation and other leisure-time occupation in the interests of social welfare; the provision of grants, goods or services, including educational services.

Age Concern Chipping Norton Trustees

Request for dispensation

BACKGROUND:

In December 2022, council approved a request for matching memorials for a family despite them exceeding cemetery regulations.

A similar situation has arisen regarding a different family who are requesting two memorials which exceed cemetery regulations.

The plot owner owns nine graves in a row – one family member was buried in this area in 2010, before cemetery regulations were updated. The two proposed memorials are to be installed either side of the existing burial. This will be the father and sister of the man buried. The plot owner wishes for the memorials to be exactly the same as the existing ones.

The memorial will be polished Blue Pearl Granite – 30” high x 30” wide x 3” thick, standing on a base 36” wide x 18” deep x 3” thick with no vase liners.

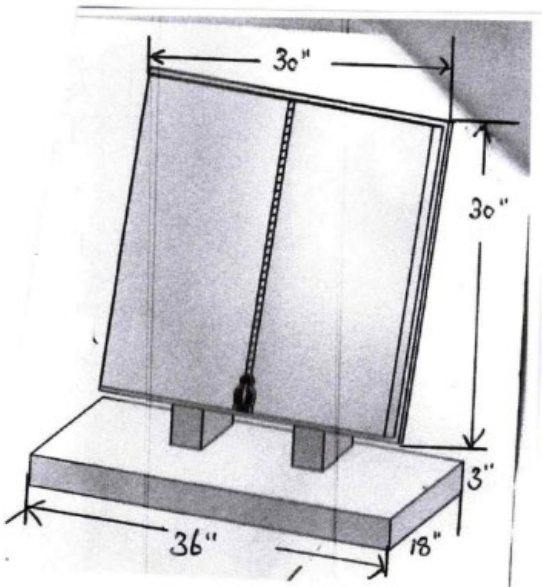

This grave is in Section 4 and will be on either side of the existing headstone (photographed below).

RECOMMENDATION:

That the Council consider granting permission for the plot owner to install matching memorials for this current request, and future requests in this family plot.



Functions which may be delegated to the Town Hall Restoration Sub Committee:

1. The Committee shall consist of 6 Town Councillors. Other organisations and residents may be invited to attend in an advisory capacity but do not have any decision-making abilities.
2. The Quorum shall be at least 3 CN Town Councillors or a third of Committee membership, whichever is greater.
3. A Chair shall be elected at the first meeting of the new municipal year
4. The Committee is an advisory committee reporting to the full Town Council and to the Community. Any advice will be reported to the full CNTC & Community for consideration.
5. The committee has no budget responsibility or delegated powers apart from those set out in paragraph 6 below.
6. The scope of the Committee will include matters relating to Chipping Norton Town Hall including:
 - Delegated powers to manage the Town Hall Restoration earmarked reserves
 - Submission of grant applications to funding bodies
 - Heritage Open DaysThis list is not exhaustive.
7. On matters that require further research, for example a more detailed report or seeking further clarification from a third party, the Committee shall have delegated power to act.
8. The Committee shall meet at least four times per year and such other occasions as deemed necessary

18. Planning Applications

1. APPLICATION NO: 26/01201/HHD
PROPOSAL: Conversion of existing detached double garage to form games room
LOCATION: 20 Howes Lane Chipping Norton Oxfordshire
 2. APPLICATION NO: 26/01069/HHD
PROPOSAL: Erection of a single storey rear extension
LOCATION: 1 Fowlers Court Chipping Norton Oxfordshire
-

Updates to note since 11 May 2026

- **Replacement hanging (externally illuminated) and wall sign together with fascia sign (externally illuminated) and awning, all to front elevation.**
6 Market Place Chipping Norton Oxfordshire OX7 5NA
Ref. No: 26/00792/ADV | Validated: Wed 15 Apr 2026 | Status: Withdrawn
- **Internal alterations to include removal of stud wall, blocking up of internal doorway, and replacement of kitchen units (retrospective)**
5 Norton Park Cotshill Gardens Chipping Norton Oxfordshire OX7 5UW
Ref. No: 26/00749/LBC | Validated: Wed 25 Mar 2026 | Status: Decided
- **Overclad existing double pitched roof using single skinned profiled metal sheeting including barge eaves and ridge flashings with the re-use of existing gutters and downpipes and the insertion of new roof lights.**
Jewson Building Supplies Station Road Chipping Norton Oxfordshire OX7 5HX
Ref. No: 26/00759/FUL | Validated: Wed 01 Apr 2026 | Status: Decided
- **Alterations to construct a new bin store attached to the retail premises at 19 High Street.**
Rear Of 19 High Street Chipping Norton Oxfordshire OX7 5AD
Ref. No: 26/00542/LBC | Validated: Thu 26 Mar 2026 | Status: Decided
- **Construction of a new bin store attached to the retail premises at 19 High Street.**
Rear Of 19 High Street Chipping Norton Oxfordshire OX7 5AD
Ref. No: 26/00541/FUL | Validated: Thu 26 Mar 2026 | Status: Decided
- **Variation of condition 2 of permission 20/03011/FUL to allow alterations to meet building regulations to include the installation of external vents, and changes to existing railings and light well grates (part retrospective).**
Hitchmans Mews Albion Street Chipping Norton Oxfordshire
Ref. No: 26/00296/S73 | Validated: Mon 16 Feb 2026 | Status: Decided
- **Internal and external alterations to include tanking the north walls at ground floor, installing insulation, trimming existing floor and ceiling joists, external vents, changes to existing railings and changes to light well grates to comply with Building regulations (part retrospective)**
Hitchmans Mews Albion Street Chipping Norton Oxfordshire
Ref. No: 26/00297/LBC | Validated: Mon 16 Feb 2026 | Status: Decided